

stella Mini

110W



Technical Specification

Water and shock protected LED fixture for general heavy duty applications. Powder coated high purity aluminium body. Quick release between fixture and ballast for fast service and mounting. Built in lens protection. Multiple rectangular light pictures via patented prismatic lens system. Extra low glare/light pollution (as per EU Night Sky Directive).

Heavy Duty bracket included. Safety chain as option.

LED packs and ballast easily replaceable.

Complies with the new strict EMI regulations. Does not interfere with WiFi or electronics.

Suitable for corrosive atmospheres, marine and mining. Available with plastic cover for use with food industry.

Use areas

RTG cranes, mobile masts, poles up to 24m, warehouses and workshops up to 24m, mining applications, heavy equipment, construction sites, general lighting in tough environments.

With plastic cover: In food loading areas (ie. grain) and above food vats.

Technical Data

Mains (input) voltage

Total weight

Wind area

Form of protection

Vibration resistance

Wind speed design

Temp. tolerance

Colour temperature

Colour rendering

Hot luminaire lumen

Lumen efficiency

LED life exp.

LM80 (Jan 25, 2017)

Light-source

Energy consumption

Start time

Ballast

Safety glass

Light dissemination

220 - 240 VAC, 50-60Hz

6.5 kg: fixture including ballast

0.032m² per fixture inc. ballast

IP 66, class I

4G during extended periods

55 m/s Hurricane class

+60°C to -40°C

5 000°K (4000°K option)

CRI 75

11 000

100lm/system watt

100 000h+ to 80% output.

L90 >60,500h

4x Nordic light DUO

110 W

1 sec. to maximum lumen output

Electronic ballast in attached IP66.

Included (hardened prismatic lens)

Several rectangular light pictures

depending on use (15° to 140°)

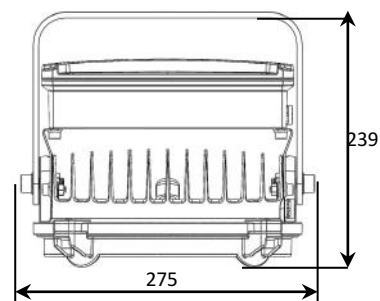
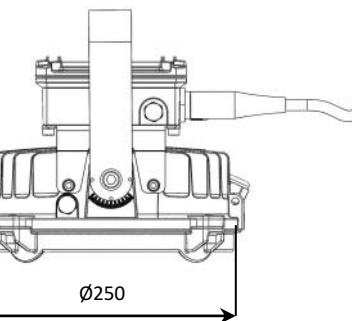
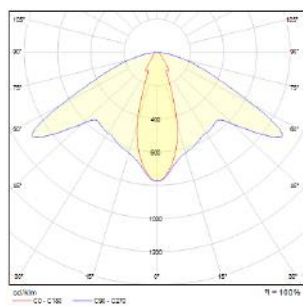
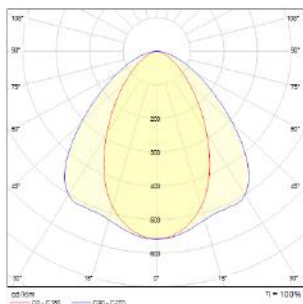
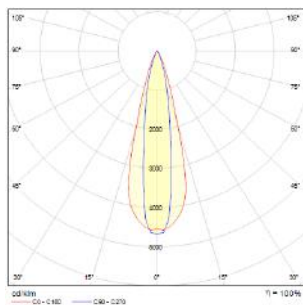

Product number:

SM11013-5, SM11036-5, SM11069-5, SM110314-5 (110W 5000°K)

SM11013-4, SM11036-4, SM11069-4, SM110314-4 (110W 4000°K)